

1 THE INFORMATION CONTAINED HEREON IS PROPRIETARY AND CONFIDENTIAL TO DYNACOM CORPORATION. AND SHALL NOT BE USED OR DISCLOSED, IN WHOLE OR IN PART WITHOUT FIRST OBTAINING THE WRITTEN PERMISSION OF DYNACOM CORPORATION. SPECIFICATIONS SUBJECT TO CHANGE WITHOUT NOTICE.

ZONE	REV.	DESCRIPTION	DATE	APPV.
-	A	INITIAL RELEASE	08/31/2020	C.Z.

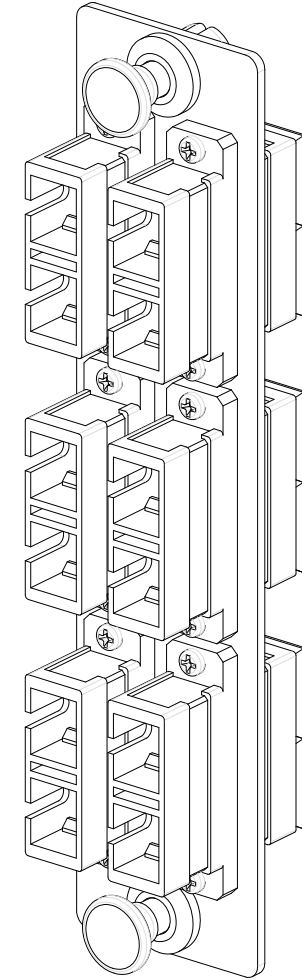
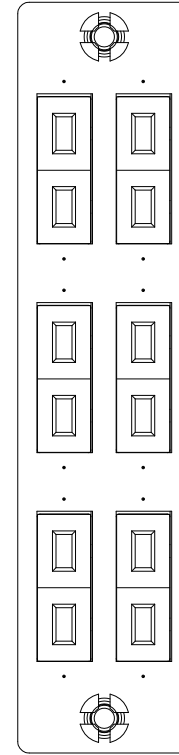
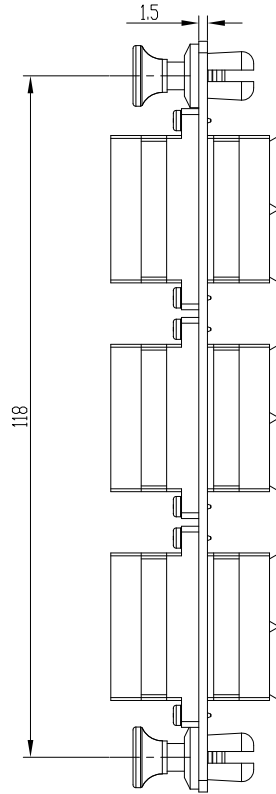
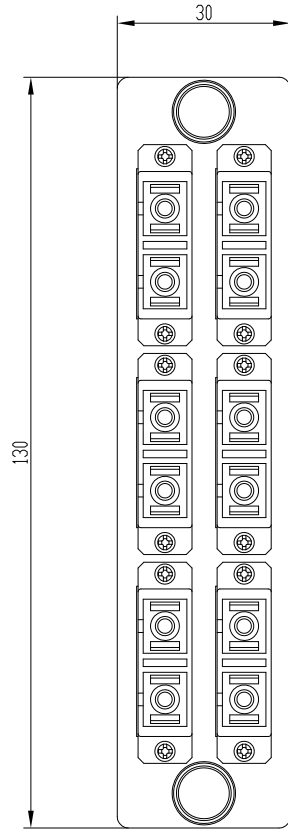

Plate Material Cold Rolled Steel
 Adapter Housing: PC Color: Aqua Sleeve: Ceramic (Zirconia)
 Adapter Plate Color FINISH-Black Powder Coat
 Plate Dimensions (LxWxH) 130x30x1.5(mm)
 Adapter Performance:
 Durability >1000 times
 Wavelength 850 & 1330nm
 Insertion Loss ≤0.2dB
 Temperature Stability Additional Loss≤0.2dB
 Operating temperature -40 to +75°C
 Storage temperature -40 to +75°C



e-mail...sales@dynacomcorp.com
 www.dynacomcorp.com

DIMENSIONS: mm

NEXT ASSY: -	DRAWN: C.Z. 08/31/20	CHECKED: EA
TITLE FIBER OPTIC PANEL SC 12F MM, AQ		DWG. NO. SHEET 1 OF 2 920A-SC-12-AQ
		REV. A