

THE INFORMATION CONTAINED HEREON IS PROPRIETARY AND CONFIDENTIAL TO DYNACOM CORPORATION. AND SHALL NOT BE USED OR DISCLOSED, IN WHOLE OR IN PART WITHOUT FIRST OBTAINING THE WRITTEN PERMISSION OF DYNACOM CORPORATION.

ZONE	REV	DESCRIPTION	DATE	APPV.
-	A	INITIAL RELEASE	04/23/10	E.A.

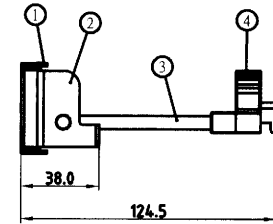

ITEM	DESCRIPTION	MATERIAL	FINISH	Q'TY
①	Front Panel Plate	Spcc(1.5t)	Black Coating	1
②	Rear Panel Plate	Spcc(1.5t)	Nickel Plating	1
③	Wire Manager Bar	SS41	Nickel Plating	1
④	Wire Manager Holder	ABS UL94V-0		1

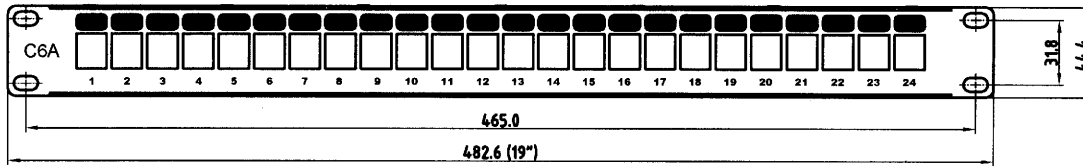
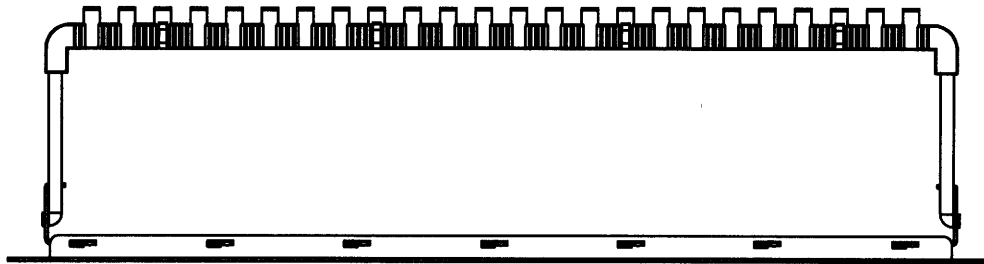
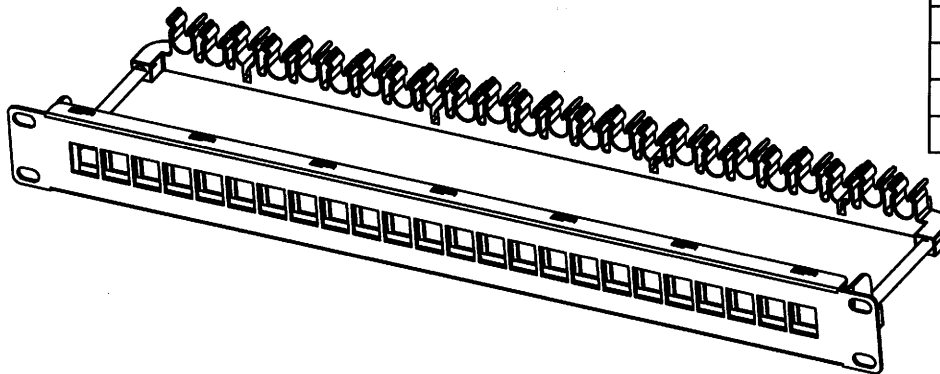

e-mail.....sales@dynacomcorp.com
Hayward, CA 94544

TOLS:

NEXT ASSY: -	DRAWN: E.A. 04/23/10	CHECKED: E.L.
TITLE: Cat6A FTP Snap-in Patch Panel 24 port		DWG. NO. 2022-24AS
		REV. A

THE INFORMATION CONTAINED HEREON IS PROPRIETARY AND CONFIDENTIAL TO DYNACOM CORPORATION. AND SHALL NOT BE USED OR DISCLOSED, IN WHOLE OR IN PART WITHOUT FIRST OBTAINING THE WRITTEN PERMISSION OF DYNACOM CORPORATION. SPECIFICATIONS SUBJECT TO CHANGE WITHOUT NOTICE.

ZONE	REV.	DESCRIPTION	DATE	APPV.
-	A	INITIAL RELEASE	05/04/2016	E.A.

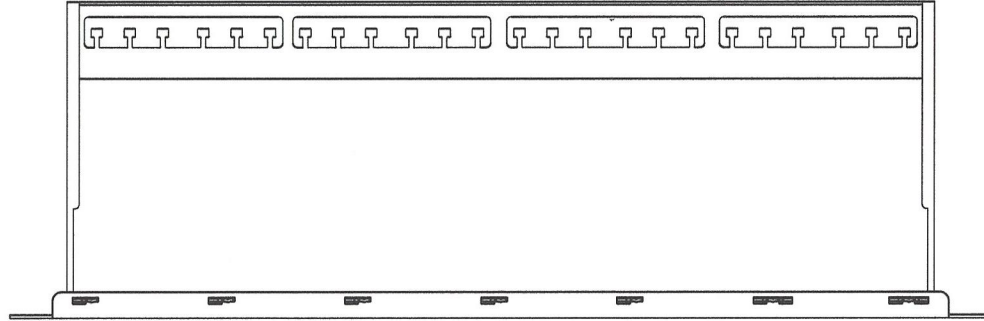

ITEM	DESCRIPTION	MATERIAL	FINISH	QTY.
1	Front Panel Plate	Spcc (1.5t)	Black Coating	1
2	Rear Panel Plate	Spcc (1.5t)	Nickel Plating	1
3	Wire Manager Bar	SS41	Nickel Plating	2
4	Mounting Screws	Steel	Black	4
5	Tie Wraps	Plastic	none	24
5	Grounding Screw (not shown)	Steel	Nickel Plating	1

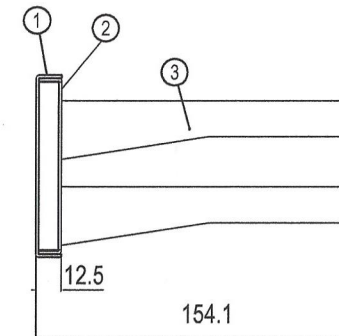
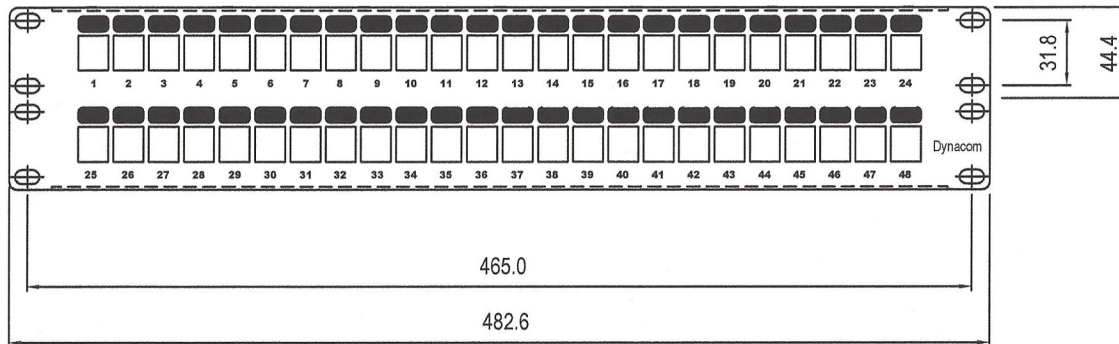

e-mail....sales@dynacomcorp.com
www.dynacomcorp.com

Tolerances: MM

NEXT ASSY: -	DRAWN: E.A. 05/04/2016	CHECKED: EA
TITLE 48-Port, Cat6A, Grounded, Blank Patch Panel	DWG. NO. 2022-48AS	SHEET 1 OF 1 REV. A