

THE INFORMATION CONTAINED HEREON IS PROPRIETARY AND CONFIDENTIAL TO DYNACOM CORPORATION. AND SHALL NOT BE USED OR DISCLOSED, IN WHOLE OR IN PART WITHOUT FIRST OBTAINING THE WRITTEN PERMISSION OF DYNACOM CORPORATION.

ZONE	REV	DESCRIPTION	DATE	APPV.
-	A	WAS 1900-WS.	07/05/07	E.A.
-	B	ADDED SHEET 2.	01/21/08	E.A.

PAINT SPECIFICATION & APPLICATION	
MANUFACTURER:	FULLER OBRIEN
PAINT NUMBER:	RFB505T2
COLOR:	BLACK RIDGE
FINISH:	SEMI GLOSS
TEXTURE:	MEDIUM TEXTURE
APPLICATION:	ELECTROSTATIC SPRAY, COLD
SUBSTRATE:	0.032 IN, CRS
PRETREATMENT:	BONDERITE 1000
CURE SCHEDULE:	10 MINS @ 400 DEG F
FILM THICKNESS:	2.5, 3.5 MILS

- NOTES:
1. MATERIAL: 14 GA. (0.0785) COLD ROLLED STEEL.
 2. FINISH: SEE PAINT SPECIFICATION TABLE.
 3. ALL HOLE DIMENSIONS ARE AFTER PAINTING.

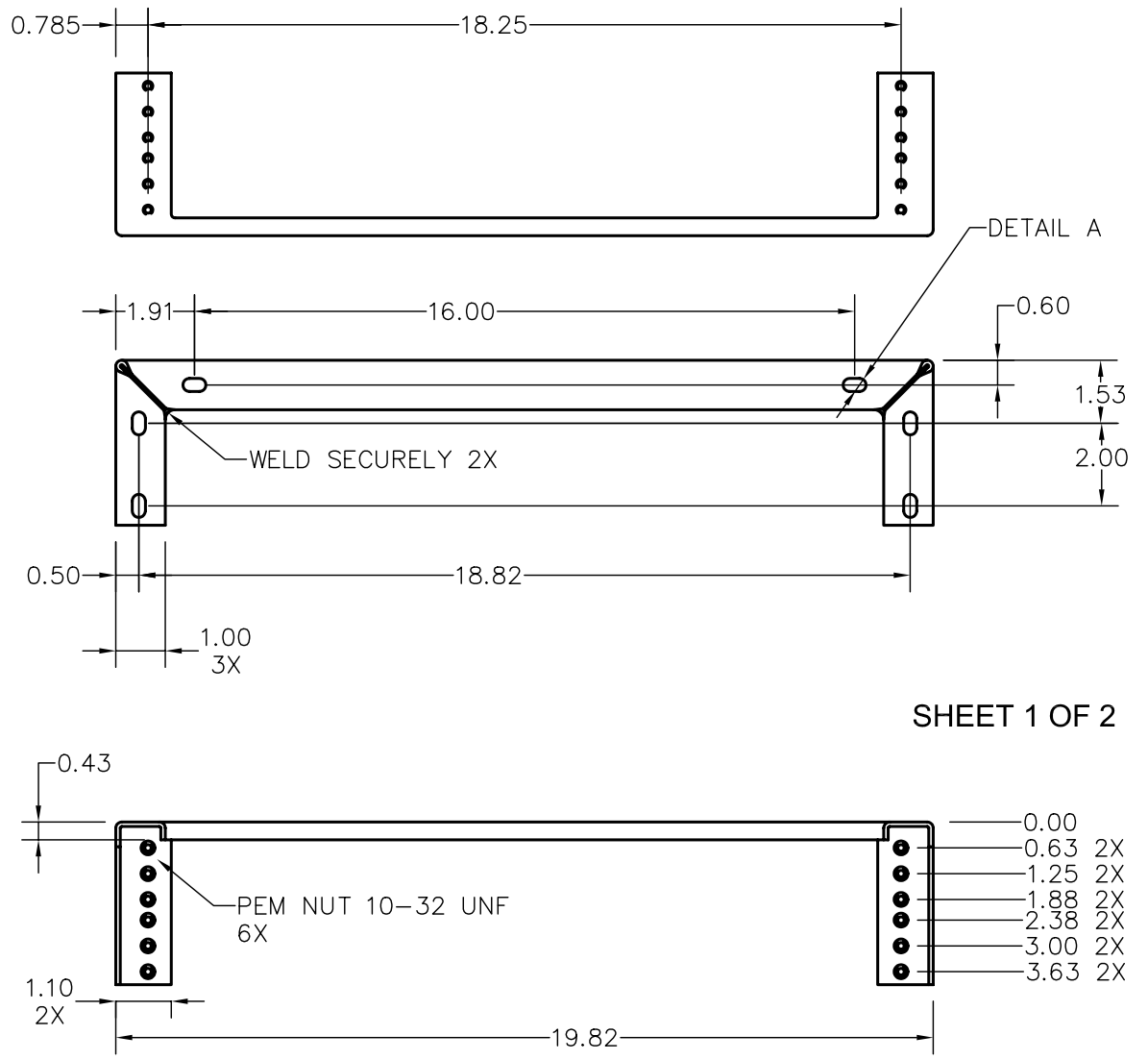
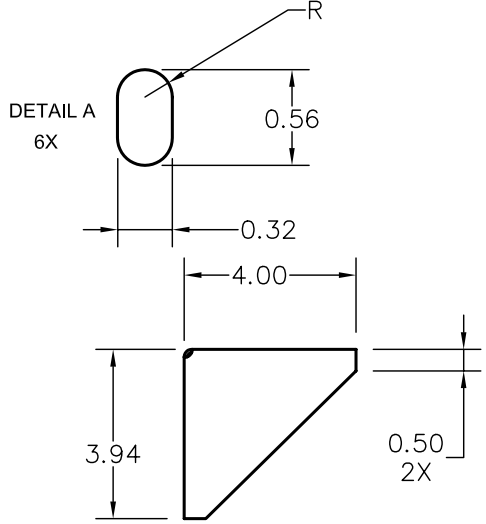

SHEET 1 OF 2

C:\DYNACOM\Logos\Dynamom NP.jpg

e-mail.....info@dynamomcorp.com
 1366 San Mateo Ave Suite 201
 South San Francisco CA 94080

TOLS. .X=+/- 0.030, .XX=+/- 0.010, .XXX=+/- .005, ANGLES=+/-0.5 DEG.			
NEXT ASSY: -	DRAWN: E.A. 05/03/07	CHECKED: Eddy Lee	
TITLE: Wall Bracket, Vertical 2RU		DWG. NO. 2016-WBV350	REV. B

THE INFORMATION CONTAINED HEREON IS PROPRIETARY AND CONFIDENTIAL TO DYNACOM CORPORATION. AND SHALL NOT BE USED OR DISCLOSED, IN WHOLE OR IN PART WITHOUT FIRST OBTAINING THE WRITTEN PERMISSION OF DYNACOM CORPORATION.

ZONE	REV	DESCRIPTION	DATE	APPV.
-	A	Released	10/12/07	E.A.
-	B	SHEET 2 ADDED.	01/21/08	E.A.

PAINT SPECIFICATION & APPLICATION

MANUFACTURER: FULLER OBRIEN
PAINT NUMBER: RFB505T2
COLOR: BLACK RIDGE
SEMI GLOSS
MEDIUM TEXTURE
ELECTROSTATIC SPRAY, COLD
SUBSTRATE: 0.032 IN, CRS
PRETREATMENT: BONDERITE 1000
CURE SCHEDULE 10 MINS @ 400 DEG F
FILM THICKNESS: 2.5, 3.5 MILS

NOTES:

1. MATERIAL: 14 GA. (0.0785) COLD ROLLED STEEL.
2. FINISH: SEE PAINT SPECIFICATION TABLE.
3. ALL HOLE DIMENSIONS ARE AFTER PAINTING.

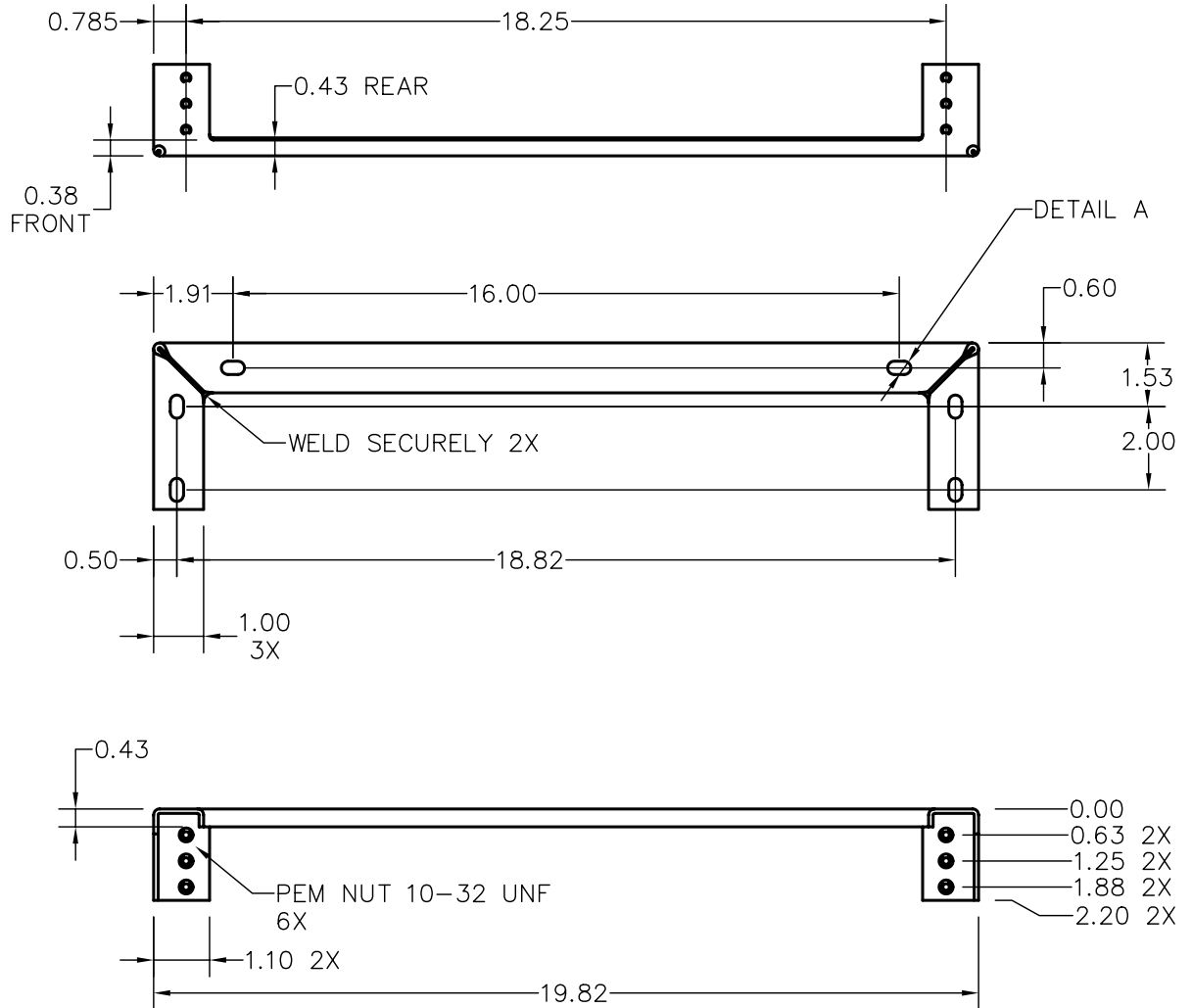
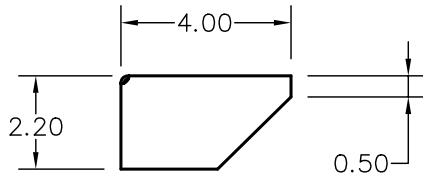
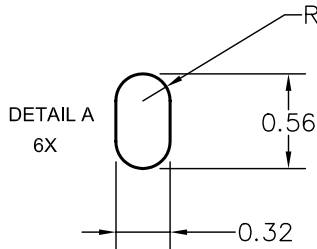

SHEET 1 OF 2



e-mail.....info@dynamcomcorp.com

1366 San Mateo Ave Suite 201
South San Francisco CA 94080

TOLS. .X=+/- 0.030, .XX=+/- 0.010, .XXX=+/- .005, ANGLES=+/-0.5 DEG.

NEXT ASSY: -	DRAWN: E.A. 10/12/07	CHECKED: Eddy Lee
TITLE: Wall Bracket, Vertical 1RU	DWG. NO. 2016-WBV175	REV. B