

THE INFORMATION CONTAINED HEREON IS PROPRIETARY AND CONFIDENTIAL TO DYNACOM CORPORATION. AND SHALL NOT BE USED OR DISCLOSED, IN WHOLE OR IN PART WITHOUT FIRST OBTAINING THE WRITTEN PERMISSION OF DYNACOM CORPORATION.

ZONE	REV.	DESCRIPTION	DATE	APPV.
	A	INITIAL RELEASE	10/02/00	E.A.
	B	UPDATED BILL OF MATERIALS LIST.	04/14/03	E.A.
	C	CHANGED DRAWING NUMBER ONLY. WAS S19REVB.	06/27/07	E.A.

NOTES:

1. MATERIAL: 16 GA (0.060 INCH) COLD ROLLED STEEL.
2. FINISH: POWDER COAT BLACK-TEXTURED.

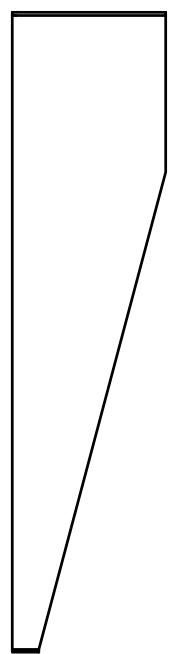
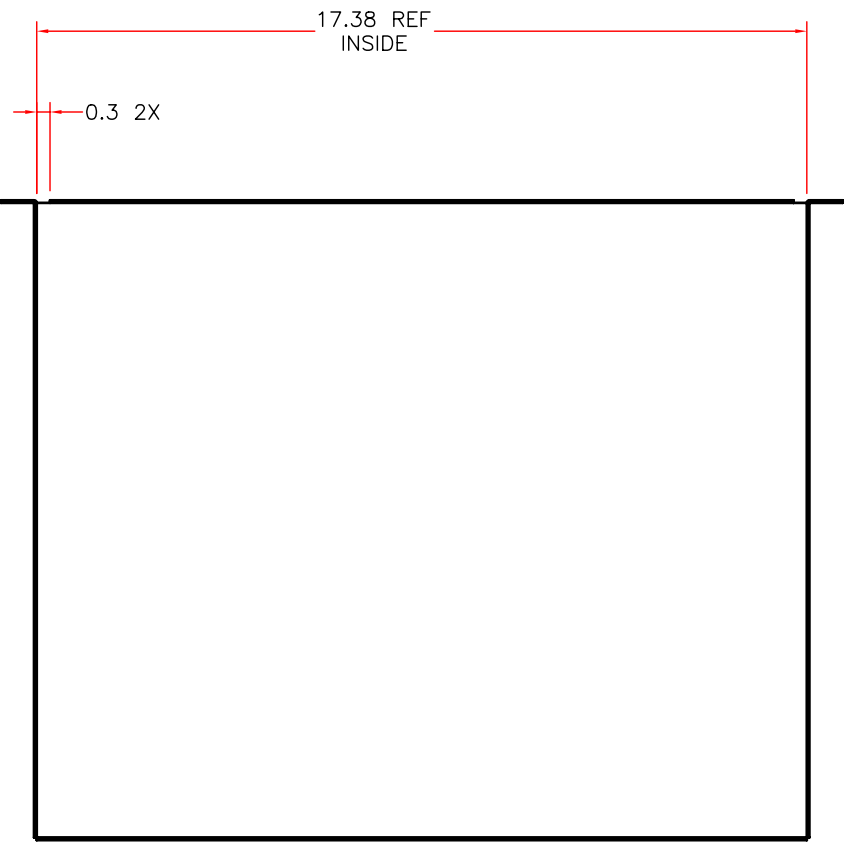

DWG: 1900-CS 1 RevC
P/N: 1900-CS
SHEET 1 OF 2

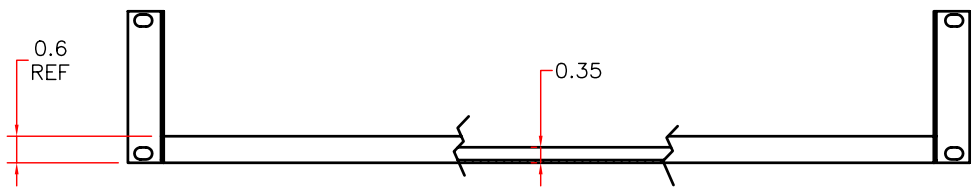

ITEM	QTY	DESCRIPTION
4	1	CARTON
3	4	#12 WASHER, LOCK, INTERNAL TOOTH, COLOR/BLACK.
2	4	SCREW, 12-24 COMBO HEAD X .75 LG. COLOR/BLACK.
1	1	CANTILEVER SHELF

SHEET 1 OF 2



e-mail.....info@dynamcomcorp.com
1366 San Mateo Ave Suite 201
South San Francisco CA 94080

TOLS. .X=+/- 0.030, .XX=+/- 0.010, .XXX=+/- .005, ANGLES=+/-0.5 DEG.			
NEXT ASSY: -	DRAWN: E.A. 10/02/00	CHECKED: Eddy Lee	
TITLE CANTILEVER SHELF, 14" DEEP		DWG. NO. 1900-CS	REV. C

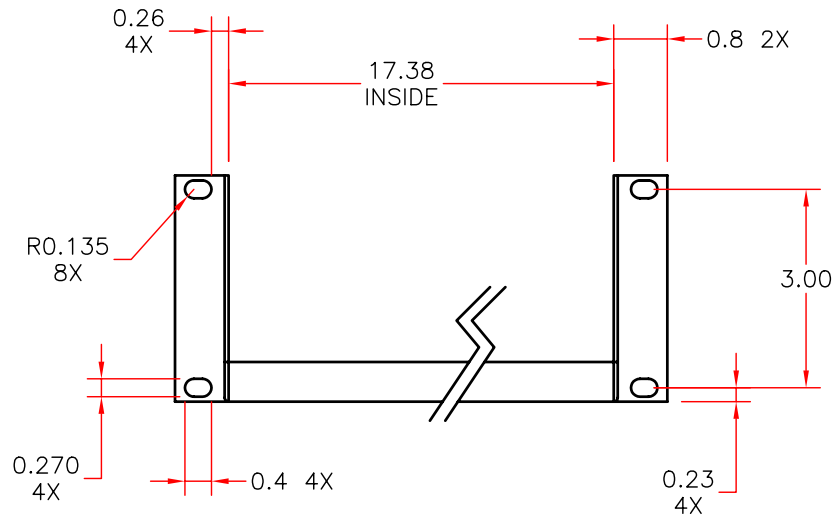
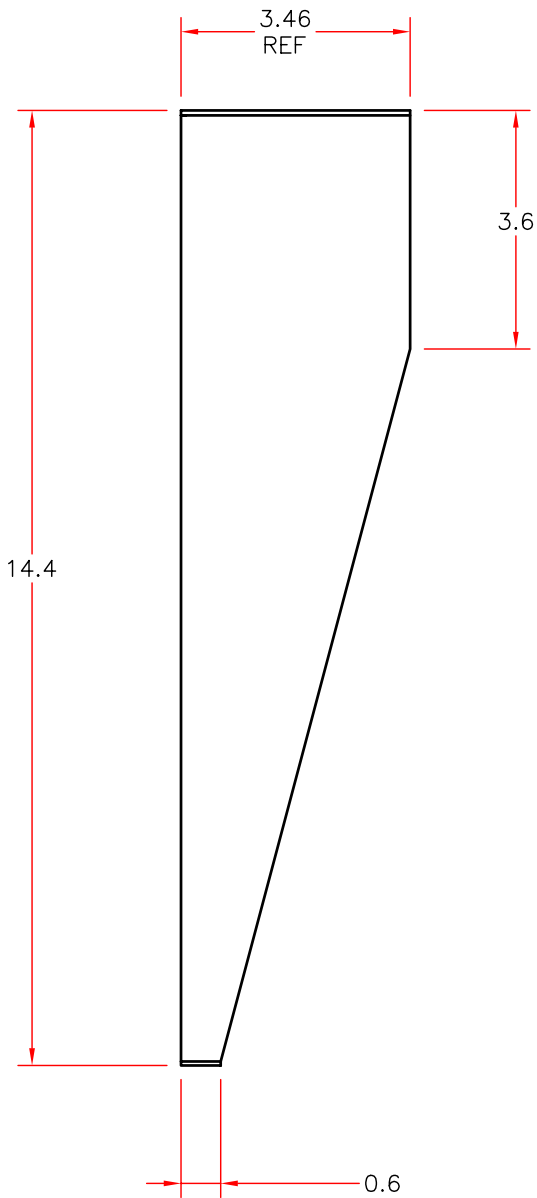

DWG: 1900-CS 2 RevC

P/N: 1900-CS

SHEET 2 OF 2



e-mail.....info@dynacomcorp.com
 1366 San Mateo Ave Suite 201
 South San Francisco CA 94080

TOLS. .X=+/- 0.030, .XX=+/- 0.010, .XXX=+/- .005, ANGLES=+/-0.5 DEG.

NEXT ASSY: -

DRAWN: E.A. 10/02/00

CHECKED: Eddy Lee

TITLE

CANTILEVER SHELF, 14" DEEP

DWG. NO.

1900-CS

REV.

C

THE INFORMATION CONTAINED HEREON IS PROPRIETARY AND CONFIDENTIAL TO DYNACOM CORPORATION. AND SHALL NOT BE USED OR DISCLOSED, IN WHOLE OR IN PART WITHOUT FIRST OBTAINING THE WRITTEN PERMISSION OF DYNACOM CORPORATION.

ZONE	REV	DESCRIPTION	DATE	APPV.
	A	INITIAL RELEASE	10/23/06	E.A.
	B	PART NUMBER WAS S19V	10/23/06	E.A.
	C	UPDATE BILL OF MATERIAL	8/17/23	E.A.

NOTES:

- MATERIAL: 16 GA (0.060 INCH) COLD ROLLED STEEL.
- FINISH: POWDER COAT BLACK-TEXTURED.

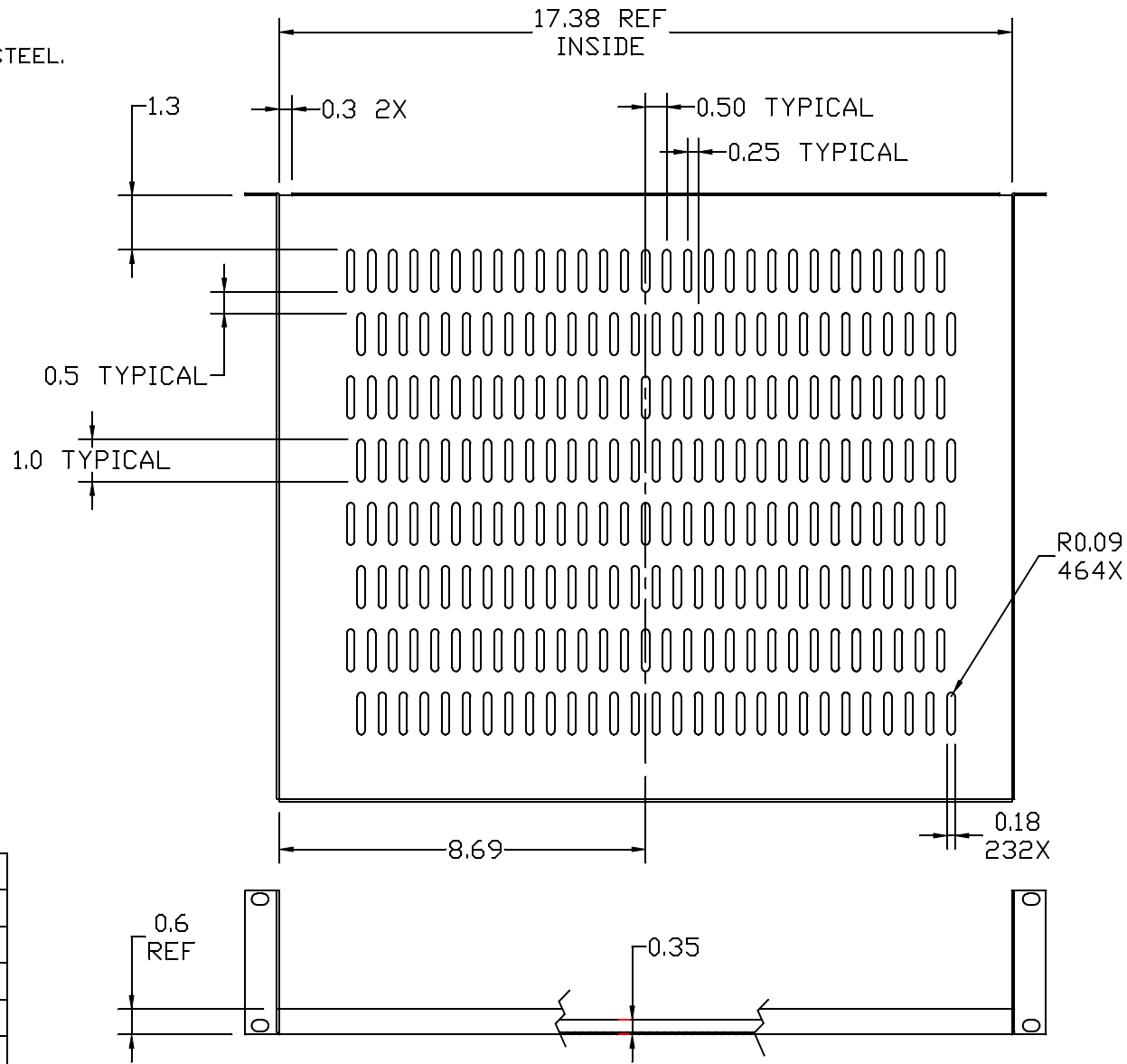
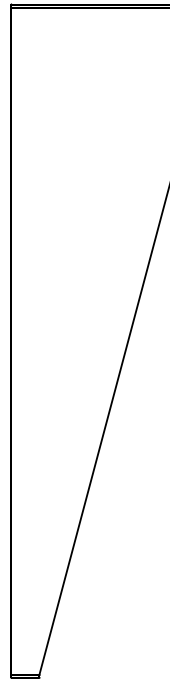

ITEM	QTY	DESCRIPTION
4	1	CARTON
3	4	# 12 WASHER, LOCK, INTERNAL TOOTH, COLOR/BLACK
2	4	SCREW, 12-24 COMBO HEAD X .75 LG. COLOR/BLACK
1	1	CANTILEVER SHELF

SHEET 1 OF 2



e-mail.....sales@dynacomcorp.com
 Hayward, California USA
 www.dynacomcorp.com

TOLS. .X=+/- 0.030, .XX=+/- 0.010, .XXX=+/- .005, ANGLES=+/-0.5 DEG.		
NEXT ASSY: -	DRAWN: E.A. 8/17/23	CHECKED: ALLEN L.
TITLE	DWG. NO.	REV.
	1900-CSV	C

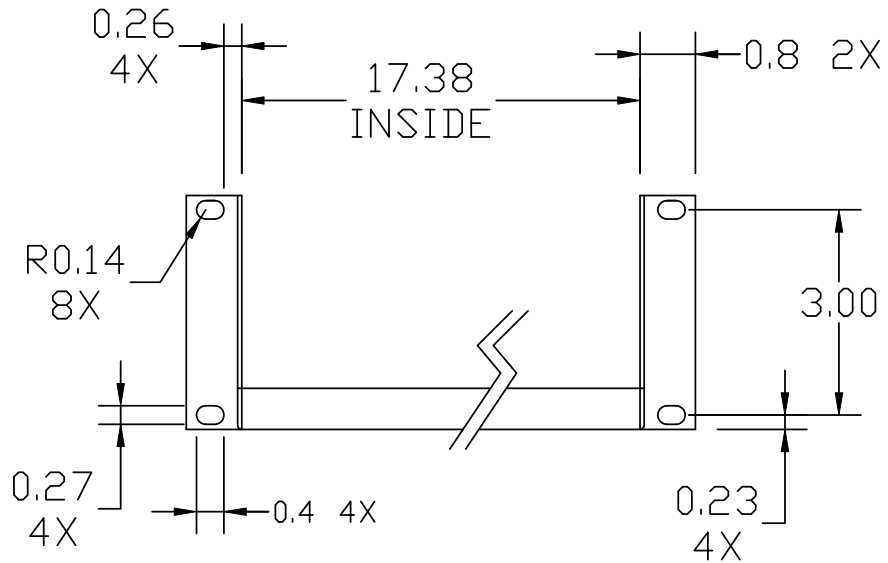
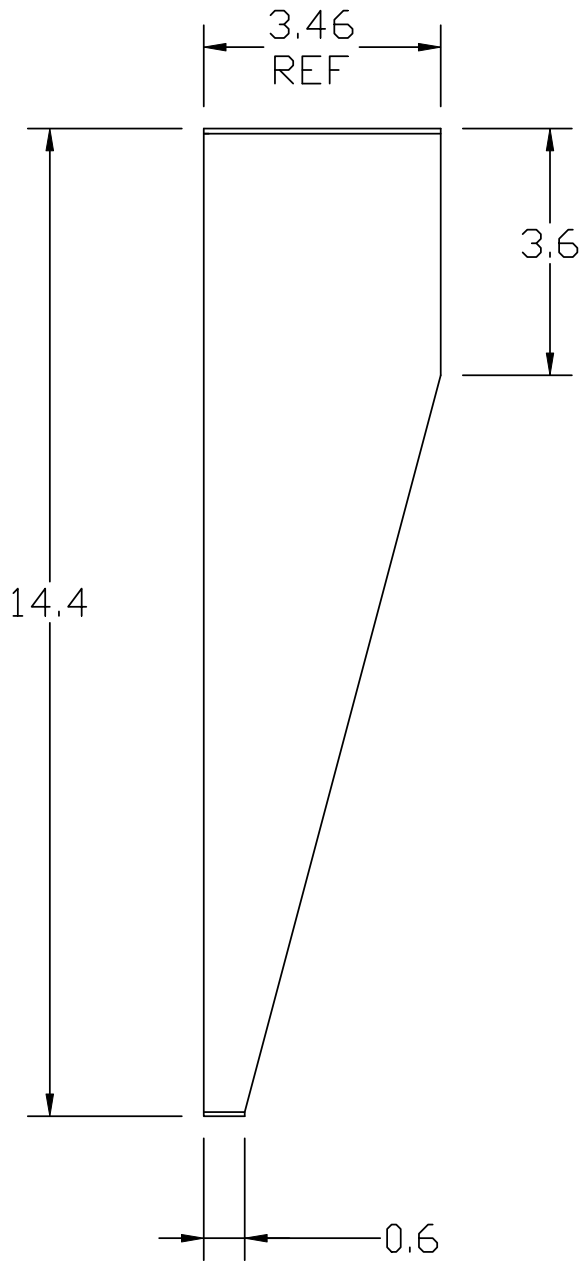

SHEET 2 OF 2



e-mail.....sales@dynacomcorp.com
 Hayward, California US
 www.dynacomcorp.com

TOLS. .X=+/- 0.030, .XX=+/- 0.010, .XXX=+/- .005, ANGLES=+/-0.5 DEG.

NEXT ASSY: -	DRAWN: E.A. 8/17/23	CHECKED: D.P.	
TITLE Cantilever Shelf, Vented		DWG. NO. 1900-CSV	REV. C