

THE INFORMATION CONTAINED HEREON IS PROPRIETARY AND CONFIDENTIAL TO DYNACOM CORPORATION. AND SHALL NOT BE USED OR DISCLOSED, IN WHOLE OR IN PART WITHOUT FIRST OBTAINING THE WRITTEN PERMISSION OF DYNACOM CORPORATION. SPECIFICATIONS SUBJECT TO CHANGE WITHOUT NOTICE.

ZONE	REV.	DESCRIPTION	DATE	APPV.
-	A	REISSUED	08/29/2017	E.A.
-	B	REDRAWN.	11/10/2017	E.A.

NOTES:

1. MATERIAL: 20 GAUGE COLD ROLLED STEEL.
2. FINISH: POWDER COAT. COLOR-SEE CHART.
3. ACCEPTS TWO 66 BLOCKS.
4. 6 'B HOLES' FORMED TO ACCEPT SHEET METAL SCREWS PROVIDED.

PART NUMBER	COLOR
183C1M	BLUE
183C2M	GREEN
183C3M	RED
183C4M	PURPLE

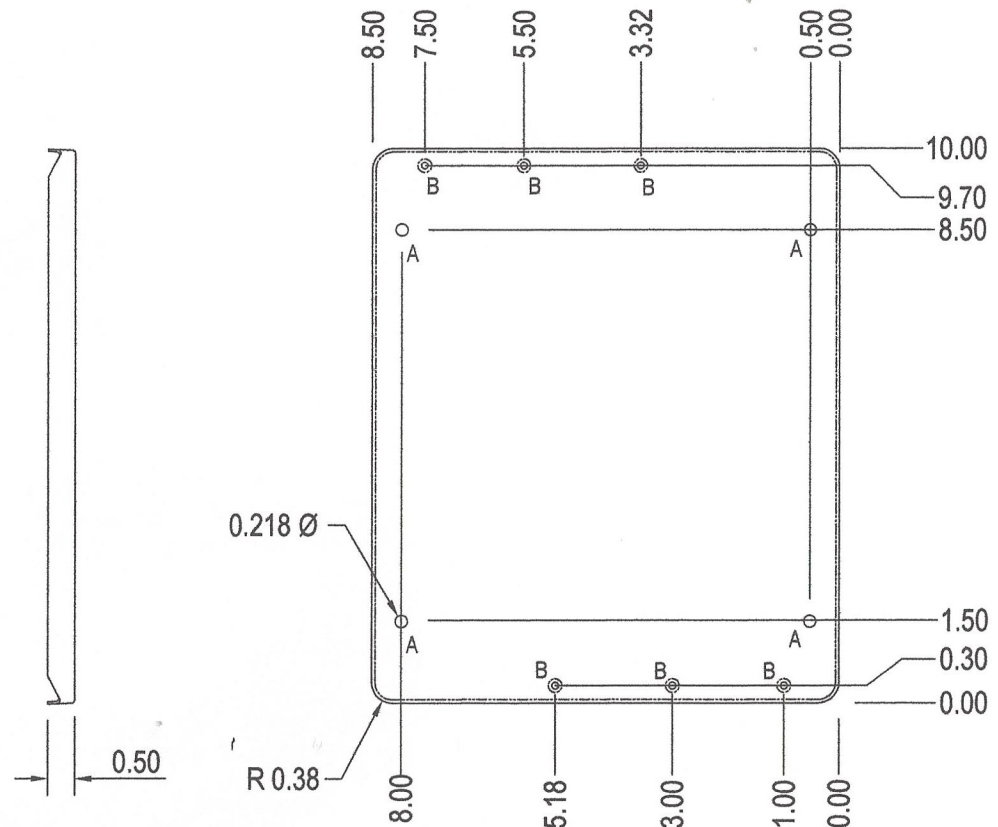
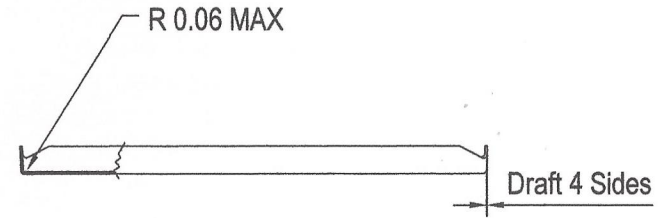

e-mail....sales@dynacomcorp.com  
www.dynacomcorp.com

TOLS: PLUS OR MINUS 0.015 INCHES ON ALL DIMENSIONS EXCEPT HOLE DIAMETERS.

NEXT ASSY: -	DRAWN: E.A. 11/10/2017	CHECKED: EA
TITLE 1x2 METAL BACKBOARD		DWG. NO. 183CXM
		SHEET 1 OF 1 REV. B