

THE INFORMATION CONTAINED HEREON IS PROPRIETARY AND CONFIDENTIAL TO DYNACOM, CORP. AND SHALL NOT BE USED OR DISCLOSED, IN WHOLE OR IN PART WITHOUT FIRST OBTAINING THE WRITTEN PERMISSION OF DYNACOM CORP.

ZONE	REV.	DESCRIPTION	DATE	APPV.
-	A	INITIAL RELEASE	08/04/00	E.A.

NOTES:

1. MATERIAL: 0.036 COLD ROLLED STEEL.
2. FINISH: POWDER COAT. COLOR-SEE CHART.
3. ALL INSIDE BEND RADII 0.09 MAX.
4. CLOSE CORNERS, BEND AS SHARP AS POSSIBLE.

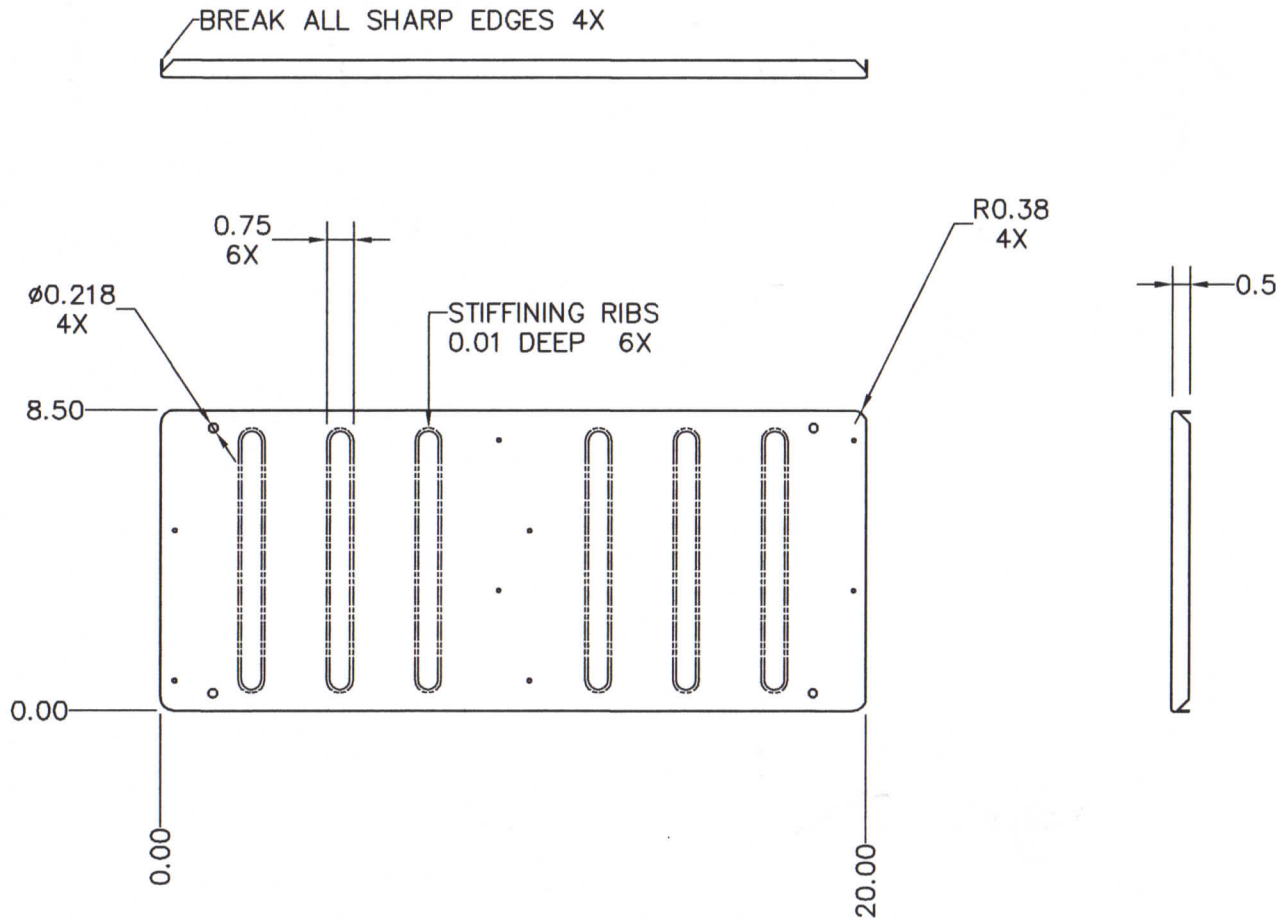

COLOR	PART NUMBER
BLUE	183A1
GREEN	183A2
RED	183A3
PURPLE	183A4
YELLOW	183A5
ORANGE	183A6



sales@dynacomcorp.com
Hayward, California

TOLS. .X=+/- 0.030, .XX=+/- 0.010, .XXX=+/- .005, ANGLES=+/-0.5 DEG.

NEXT ASSY: -	DRAWN: E.A. 02/16/04	CHECKED: Eddy Lee
TITLE: BACKBOARD	DWG. NO. 183AXM	SHEET 1 OF 1 REV. B