

THE INFORMATION CONTAINED HEREON IS PROPRIETARY AND CONFIDENTIAL TO DYNACOM CORPORATION, AND SHALL NOT BE USED OR DISCLOSED, IN WHOLE OR IN PART, WITHOUT FIRST OBTAINING THE WRITTEN PERMISSION FROM DYNACOM CORPORATION.

ZONE	REV	DESCRIPTION	DATE	APPV.
-	A	RELEASED.	10/13/2008	E.A.

NOTES:

1. MATERIAL: ABS & MUST MEET RATING 94V-0.
COLOR: OPTIONAL.
2. PART TO BE FREE BURRS, SCRATCHES, SPOTS, SUCKS OR OTHER IMPERFECTIONS THAT MAY PREJUDICE THE APPEARANCE OR FUNCTION.
3. EXTRACTION ANGLES TO BE 0°30' MAXIMUM, WHENEVER NOT MENTIONED.
4. UNLESS OTHERWISE SPECIFIED TOLERANCE TO BE FOLLOWING: (I) LINEAR: $\pm 0.2\text{mm}$.
(II) ANGULAR: 0°30'.
5. TEXTURE: MT11020

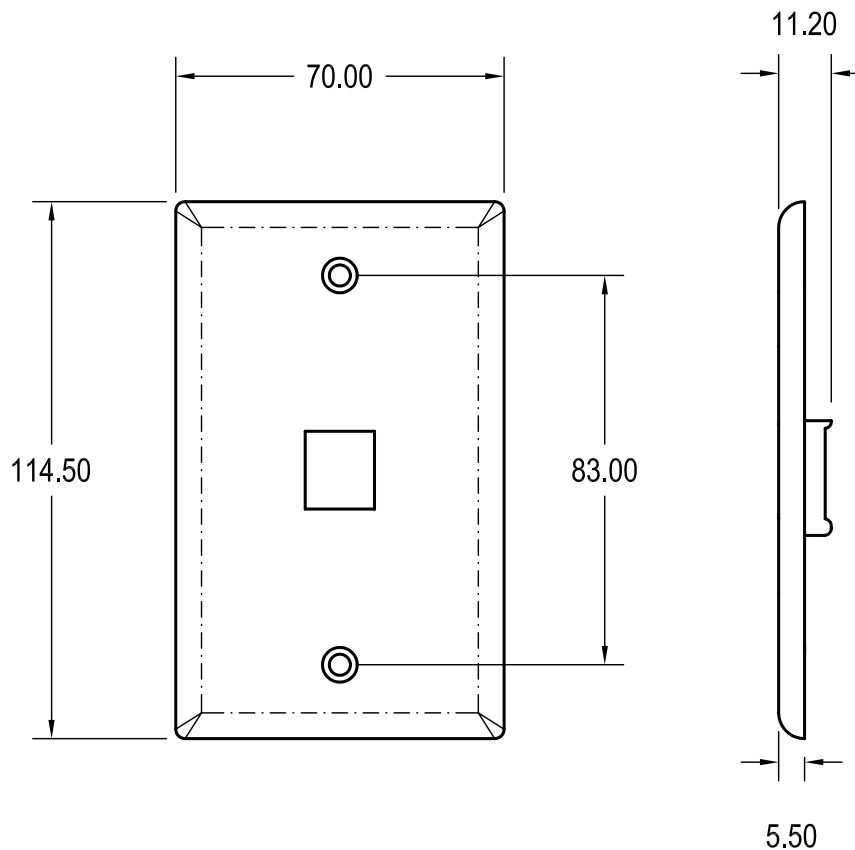

e-mail.....sales@dynacomcorp.com
31082 San Antonio Street
Hayward, California 94544

Dimensions: mm - DO NOT SCALE DRAWING

NEXT ASSY-	DRAWN: E.A.	CHECKED: E.A.
TITLE: 2-Port Wallplate	DWG. NO. 10600-P2-XX	SHEET 1 OF 1 REV. A

THE INFORMATION CONTAINED HEREON IS PROPRIETARY AND CONFIDENTIAL TO DYNACOM CORPORATION, AND SHALL NOT BE USED OR DISCLOSED, IN WHOLE OR IN PART, WITHOUT FIRST OBTAINING THE WRITTEN PERMISSION FROM DYNACOM CORPORATION.

ZONE	REV	DESCRIPTION	DATE	APPV.
-	A	RELEASED.	10/13/2008	E.A.

NOTES:

1. MATERIAL: ABS & MUST MEET RATING 94V-0.
COLOR: OPTIONAL.
2. PART TO BE FREE BURRS, SCRATCHES, SPOTS, SUCKS OR OTHER IMPERFECTIONS THAT MAY PREJUDICE THE APPEARANCE OR FUNCTION.
3. EXTRACTION ANGLES TO BE 0°30' MAXIMUM, WHENEVER NOT MENTIONED.
4. UNLESS OTHERWISE SPECIFIED TOLERANCE TO BE FOLLOWING: (I) LINEAR: $\pm 0.2\text{mm}$.
(II) ANGULAR: 0°30'.
5. TEXTURE: MT11020

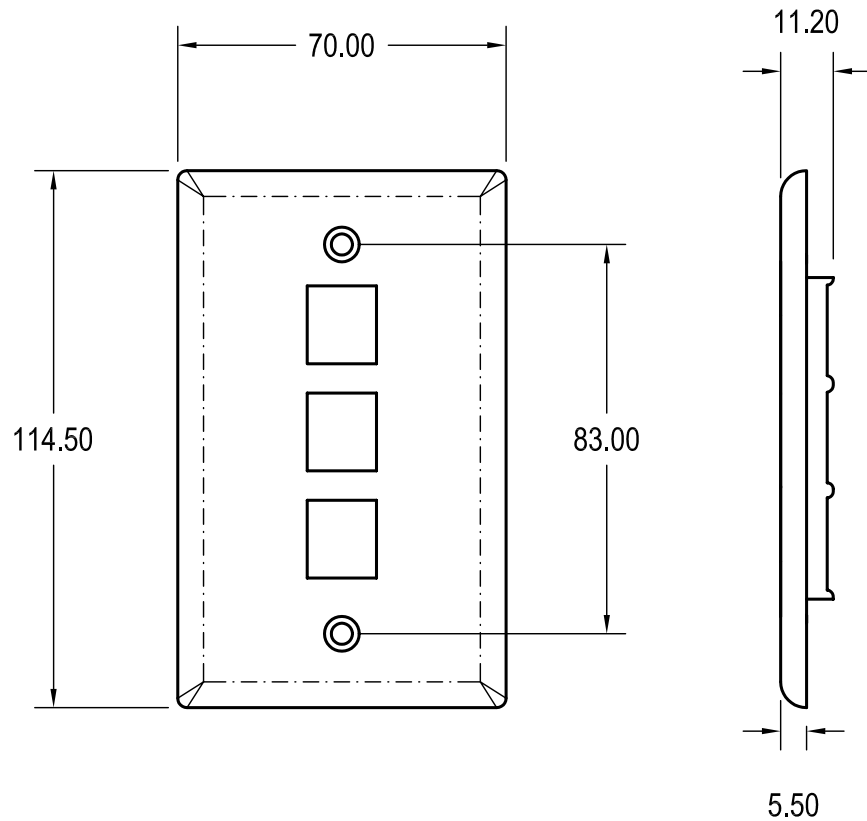

e-mail.....sales@dynacomcorp.com
31082 San Antonio Street
Hayward, California 94544

Dimensions: mm - DO NOT SCALE DRAWING

NEXT ASSY-	DRAWN: E.A.	CHECKED: E.A.
TITLE: 3-Port Wallplate	DWG. NO. 10600-P3-XX	SHEET 1 OF 1 REV. A

THE INFORMATION CONTAINED HEREON IS PROPRIETARY AND CONFIDENTIAL TO DYNACOM CORPORATION, AND SHALL NOT BE USED OR DISCLOSED, IN WHOLE OR IN PART, WITHOUT FIRST OBTAINING THE WRITTEN PERMISSION FROM DYNACOM CORPORATION.

ZONE	REV	DESCRIPTION	DATE	APPV.
-	A	RELEASED.	10/13/2008	E.A.

NOTES:

1. MATERIAL: ABS & MUST MEET RATING 94V-0.
COLOR: OPTIONAL.
2. PART TO BE FREE BURRS, SCRATCHES, SPOTS, SUCKS OR OTHER IMPERFECTIONS THAT MAY PREJUDICE THE APPEARANCE OR FUNCTION.
3. EXTRACTION ANGLES TO BE 0°30' MAXIMUM, WHENEVER NOT MENTIONED.
4. UNLESS OTHERWISE SPECIFIED TOLERANCE TO BE FOLLOWING: (I) LINEAR: $\pm 0.2\text{mm}$.
(II) ANGULAR: 0°30'.
5. TEXTURE: MT11020

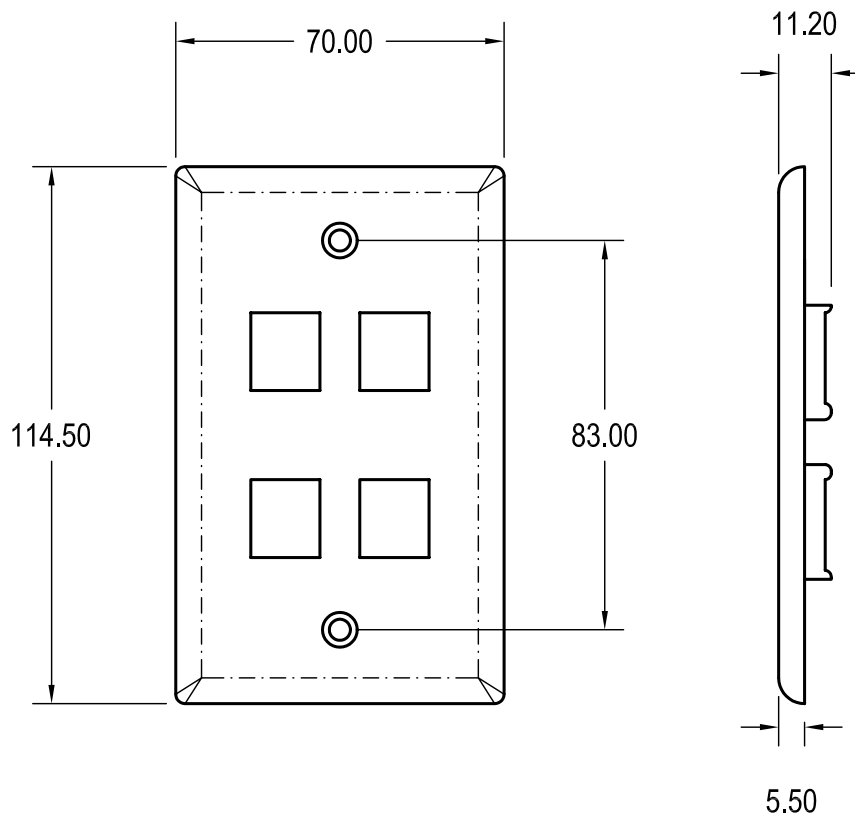

e-mail.....sales@dynacomcorp.com
31082 San Antonio Street
Hayward, California 94544

Dimensions: mm - DO NOT SCALE DRAWING

NEXT ASSY-	DRAWN: E.A.	CHECKED: E.A.
TITLE: 4-Port Wallplate	DWG. NO. 10600-P4-XX	SHEET 1 OF 1 REV. A

THE INFORMATION CONTAINED HEREON IS PROPRIETARY AND CONFIDENTIAL TO DYNACOM CORPORATION, AND SHALL NOT BE USED OR DISCLOSED, IN WHOLE OR IN PART, WITHOUT FIRST OBTAINING THE WRITTEN PERMISSION FROM DYNACOM CORPORATION.

ZONE	REV	DESCRIPTION	DATE	APPV.
-	A	RELEASED.	10/13/2008	E.A.

NOTES:

1. MATERIAL: ABS & MUST MEET RATING 94V-0. COLOR: OPTIONAL.
2. PART TO BE FREE BURRS, SCRATCHES, SPOTS, SUCKS OR OTHER IMPERFECTIONS THAT MAY PREJUDICE THE APPEARANCE OR FUNCTION.
3. EXTRACTION ANGLES TO BE 0°30' MAXIMUM, WHENEVER NOT MENTIONED.
4. UNLESS OTHERWISE SPECIFIED TOLERANCE TO BE FOLLOWING: (I) LINEAR: ± 0.2mm. (II) ANGULAR: 0°30'.
5. TEXTURE: MT11020

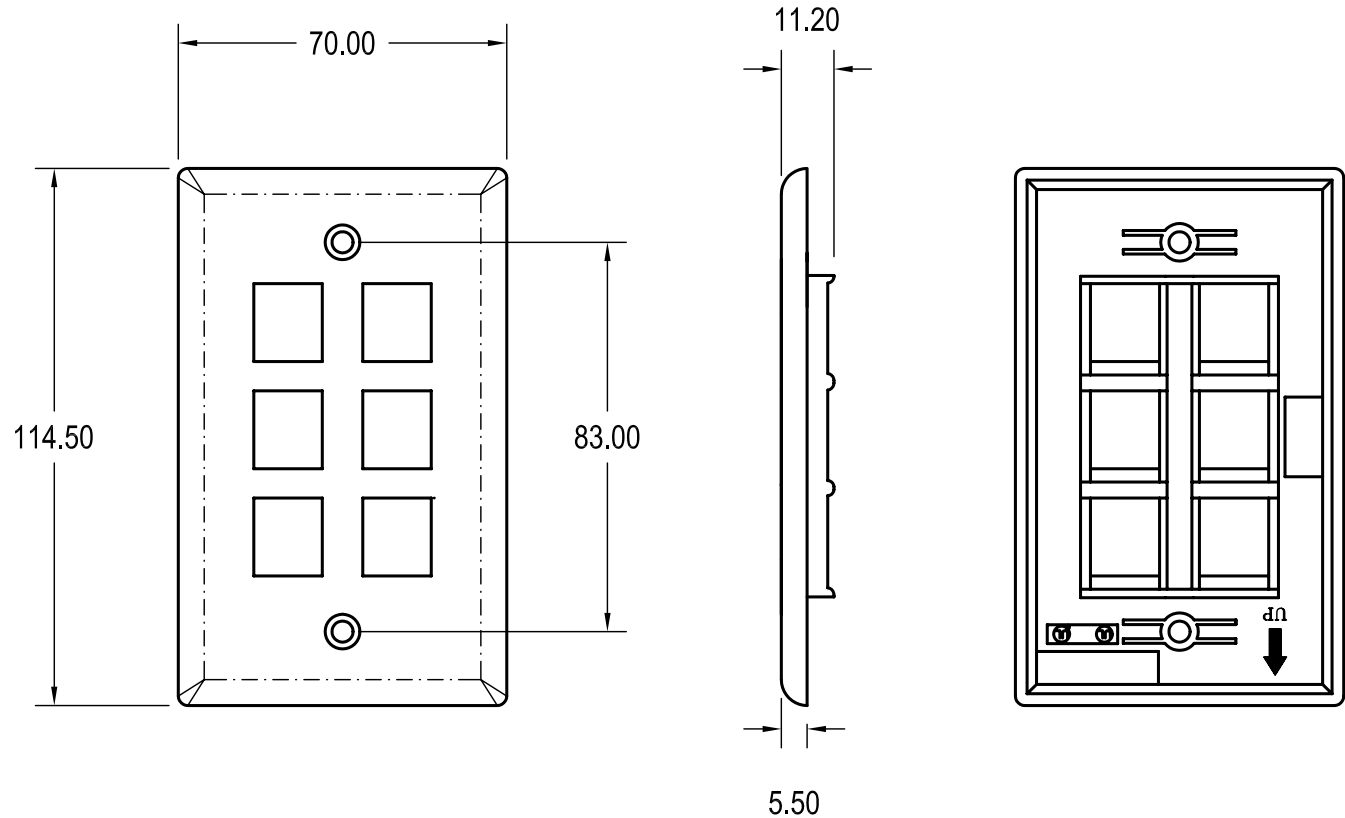

e-mail.....sales@dynacomcorp.com

31082 San Antonio Street
Hayward, California 94544

Dimensions: mm - DO NOT SCALE DRAWING

NEXT ASSY-	DRAWN: E.A.	CHECKED: E.A.
TITLE: 6-Port Wallplate	DWG. NO. 10600-P6-XX	SHEET 1 OF 1 REV. A