

THE INFORMATION CONTAINED HEREON IS PROPRIETARY AND CONFIDENTIAL TO DYNACOM CORPORATION AND SHALL NOT BE USED OR DISCLOSED, IN WHOLE OR IN PART WITHOUT FIRST OBTAINING THE WRITTEN PERMISSION OF DYNACOM CORPORATION. SPECIFICATIONS ARE SUBJECT TO CHANGE WITHOUT NOTICE.

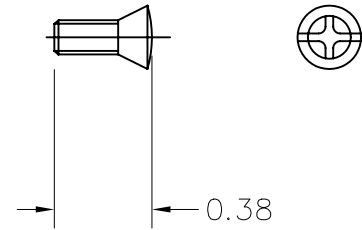
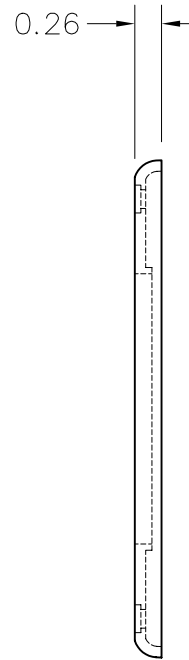
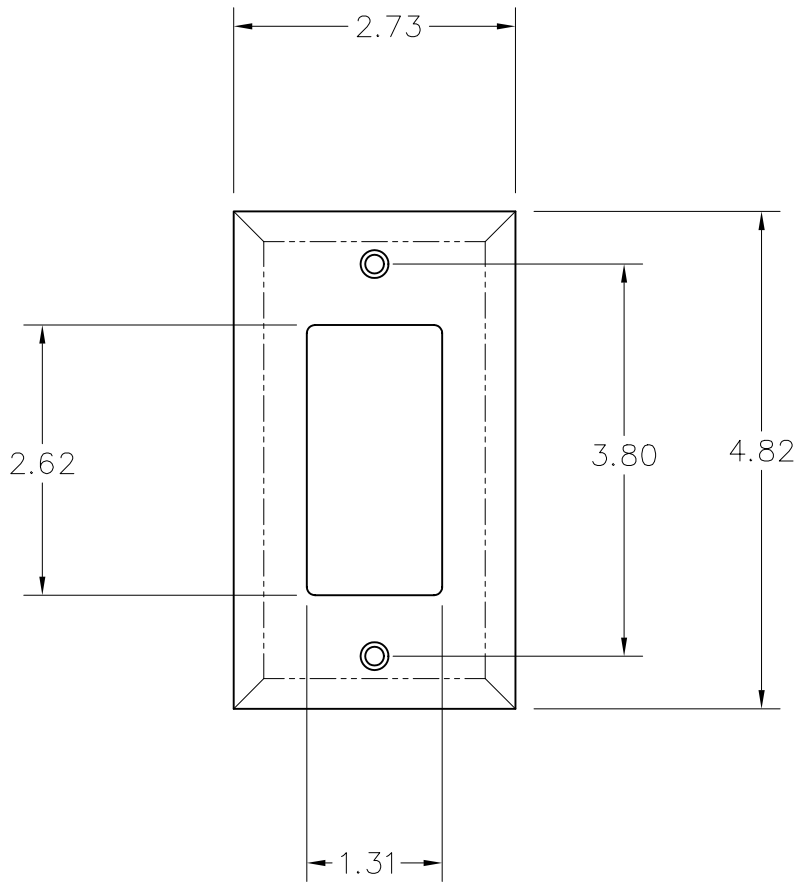

SCREW, MOUNTING

NOTES:
 1. XXX INDICATES COLOR
 WHT = ELECTRICAL WHITE

2	2	-	SCREW, 6-32 TYPE F, CHROME PLATED
1	1	10600-PD1	DECOR SINGLE OUTLET
ITEM	QTY	PART NO.	DESCRIPTION



e-mail.....info@dynacomcorp.com
 1366 San Mateo Ave Suite 201
 South San Francisco CA 94080

TITLE	DWG. NO.	SHEET 1 OF 1	REV.
SINGLE-GANG DECOR WALLPLATE	10600-PD1-XXX		

1 2 3 4

THE INFORMATION CONTAINED HEREON IS PROPRIETARY AND CONFIDENTIAL TO DYNACOM CORPORATION AND SHALL NOT BE USED OR DISCLOSED, IN WHOLE OR IN PART WITHOUT FIRST OBTAINING THE WRITTEN PERMISSION OF DYNACOM CORPORATION. SPECIFICATIONS ARE SUBJECT TO CHANGE WITHOUT NOTICE.

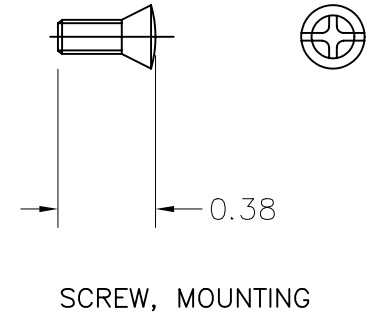
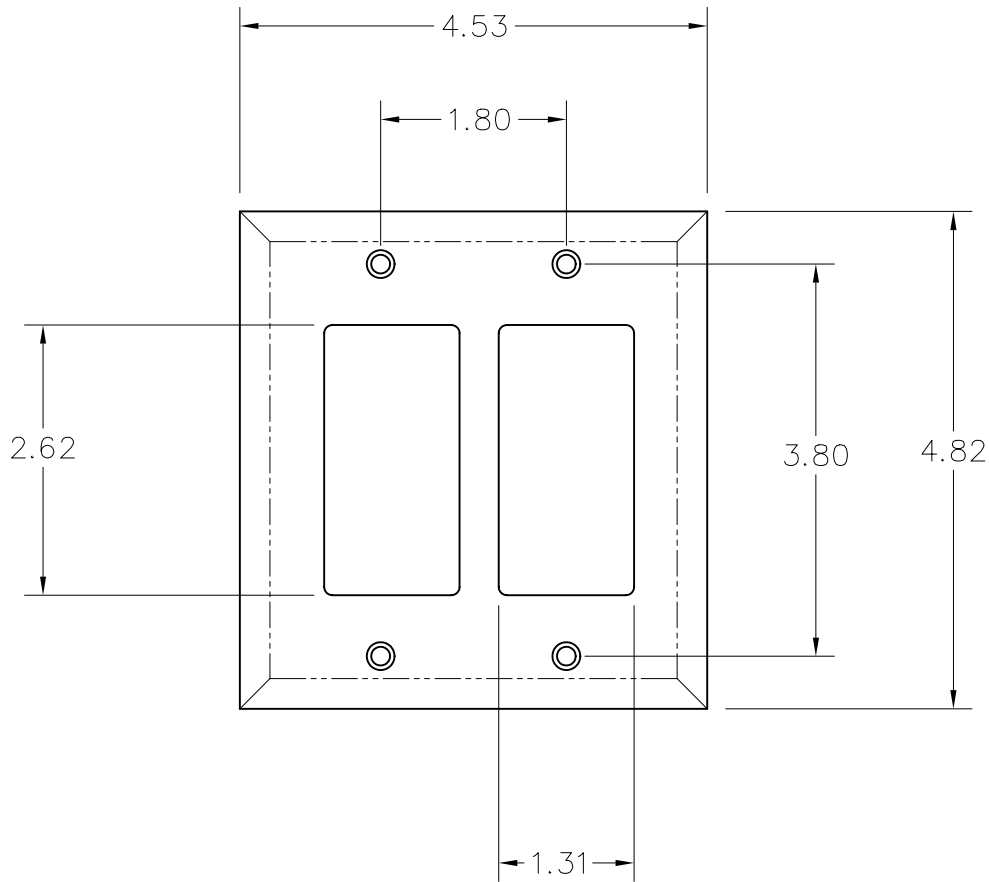

NOTES:
 1. XXX INDICATES COLOR
 WHT = ELECTRICAL WHITE

2	4	-	SCREW, 6-32 TYPE F, NICKEL PLATED
1	1	10600-PD2	DECOR DUAL OUTLET
ITEM	QTY	PART NO.	DESCRIPTION



e-mail.....info@dynacomcorp.com
 1366 San Mateo Ave Suite 201
 South San Francisco CA 94080

TITLE
 DUAL-GANG DECOR WALLPLATE

DWG. NO. SHEET 1 OF 1 REV.
 10600-PD2-XXX

4

3

2

1

THE INFORMATION CONTAINED HEREON IS PROPRIETARY AND CONFIDENTIAL TO DYNACOM CORPORATION AND SHALL NOT BE USED OR DISCLOSED, IN WHOLE OR IN PART WITHOUT FIRST OBTAINING THE WRITTEN PERMISSION OF DYNACOM CORPORATION.
 SPECIFICATIONS ARE SUBJECT TO CHANGE WITHOUT NOTICE.

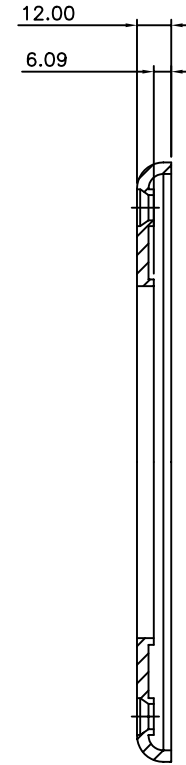
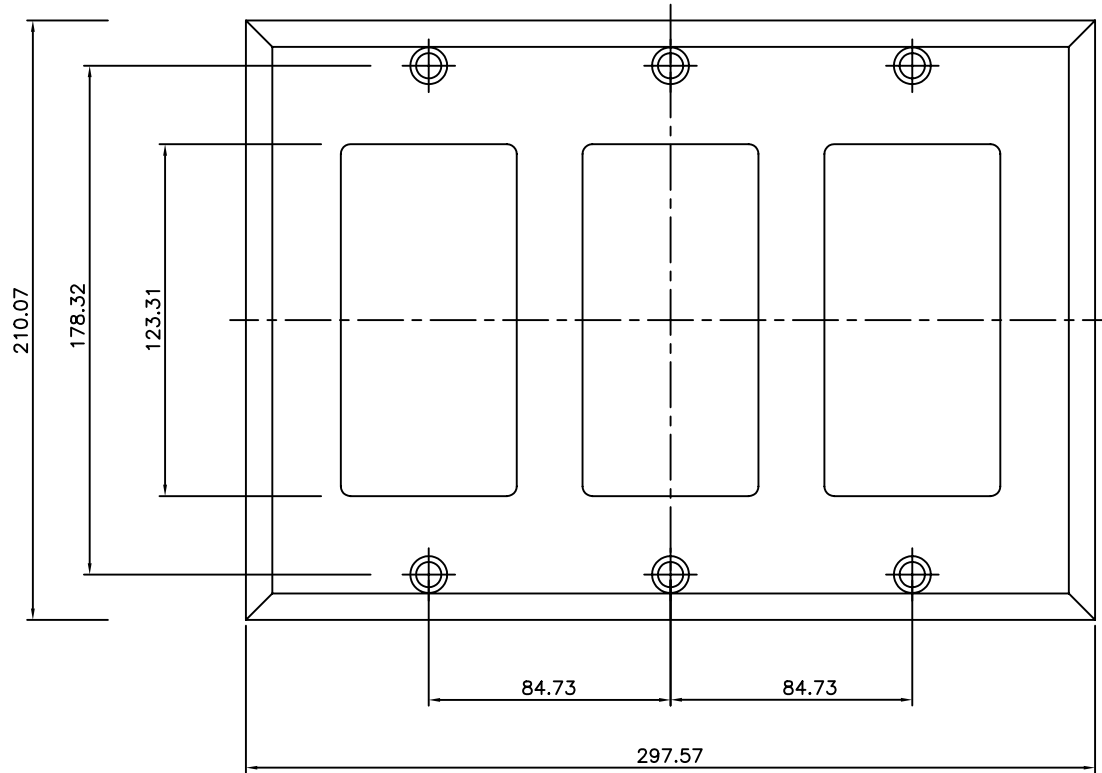

PACKAGE KIT:

SCREW(#6-32X5/16)

NOTES:
 1.MATERIAL: ABS UL 94V-0.
 COLOR: ELECTRICAL WHITE

UNLESS OTHERWISE SPECIFIED: TOLERANCES		PROJECT ID 10600-PD3-XXX		TITLE	
DECIMAL	~20 ±0.1mm	ANGULAR	±0°50'	TRIPLE GANG DECORA FACEPLATE	
OVER 20~60	±0.15mm			FILE	DATE
OVER 60~	±0.2mm				
MATERIAL	ABS 94V-0	DRAWN		SIZE	DRAWING NUMBER
SURFACE		CHECK		PART NUMBER	REV
FINISH		APPROVED		SCALE	
				UNIT	SHEET

4

3

2

1

THE INFORMATION CONTAINED HEREON IS PROPRIETARY AND CONFIDENTIAL TO DYNACOM CORPORATION AND SHALL NOT BE USED OR DISCLOSED, IN WHOLE OR IN PART WITHOUT FIRST OBTAINING THE WRITTEN PERMISSION OF DYNACOM CORPORATION. SPECIFICATIONS ARE SUBJECT TO CHANGE WITHOUT NOTICE.

D

C

B

A

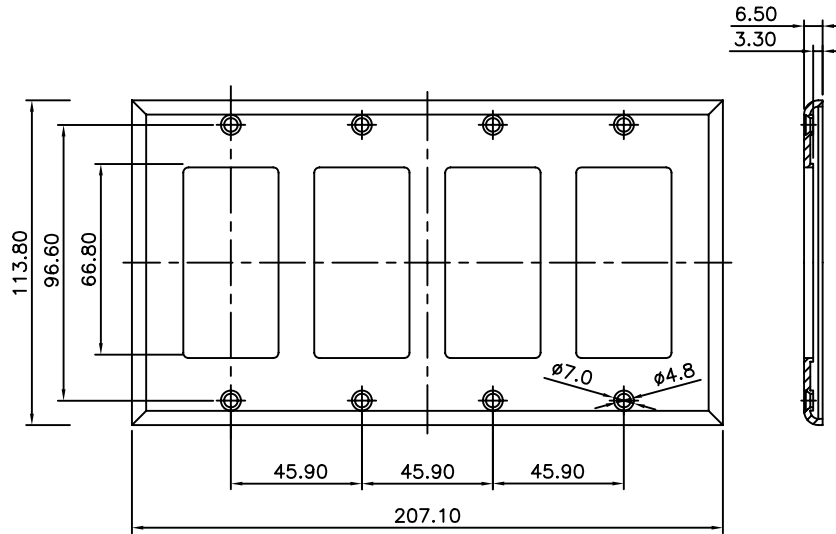

PACKAGE KIT:



SCREW(#6-32X5/16)

NOTES:

- 1.MATERIAL: ABS UL 94V-0.
- COLOR: ELECTRICAL WHITE

UNLESS OTHERWISE SPECIFIED: TOLERANCES		PROJECT ID 10600-PD4-XXX		TITLE	
DECIMAL	~20 ±0.1mm	ANGULAR	±0°50'	QUAD GANG DECOR WALLPLATE	
OVER 20~60	±0.15mm			SIZE	DRAWING NUMBER
OVER 60~	±0.2mm			PART NUMBER	REV
MATERIAL	ABS 94V-0	DRAWN			
SURFACE		CHECK			
FINISH		APPROVED		SCALE	UNIT
				mm	SHEET