

4

3

2

1

THE INFORMATION CONTAINED HEREON IS PROPRIETARY AND CONFIDENTIAL TO DYNACOM CORPORATION AND SHALL NOT BE USED OR DISCLOSED, IN WHOLE OR IN PART WITHOUT FIRST OBTAINING THE WRITTEN PERMISSION OF DYNACOM CORPORATION. SPECIFICATIONS ARE SUBJECT TO CHANGE WITHOUT NOTICE.

D

C

B

A

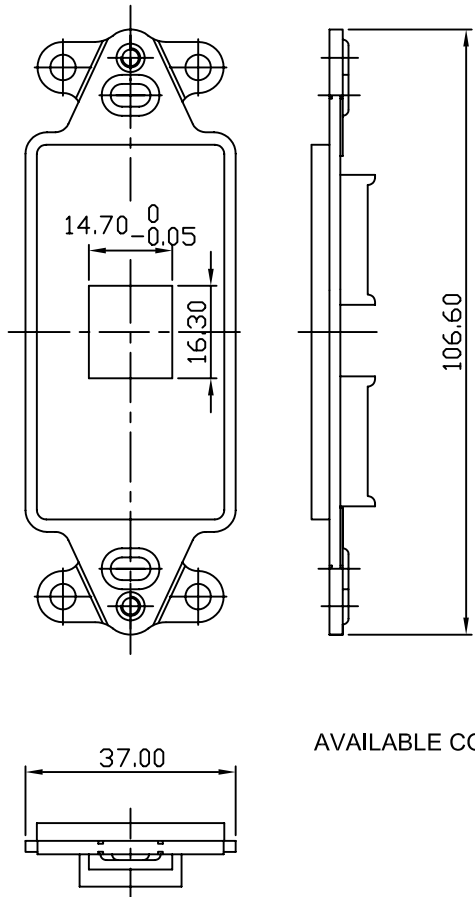

AVAILABLE COLORS: ELECTRICAL WHITE

UNLESS OTHERWISE SPECIFIED: TOLERANCES		PROJECT ID 10600-PDF1-XXX		TITLE 1-PORT FRAME FOR DECOR WALLPLATE			
.X ± .016	.X ± 0.2	X ± 1°	FILE	DATE			
.XX ± .008	.XX ± 0.1	.X ± .5°	MATERIAL	DRAWN			
.XXX ± .004			SURFACE	CHECK	SIZE		
			FINISH	APPROVED	DRAWING NUMBER	PART NUMBER	REV
				SCALE	UNIT	mm	SHEET

1 2 3 4

THE INFORMATION CONTAINED HEREON IS PROPRIETARY AND CONFIDENTIAL TO DYNACOM CORPORATION AND SHALL NOT BE USED OR DISCLOSED, IN WHOLE OR IN PART WITHOUT FIRST OBTAINING THE WRITTEN PERMISSION OF DYNACOM CORPORATION. SPECIFICATIONS ARE SUBJECT TO CHANGE WITHOUT NOTICE.

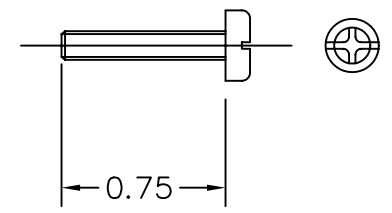
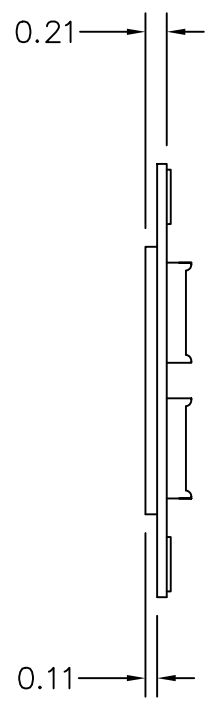
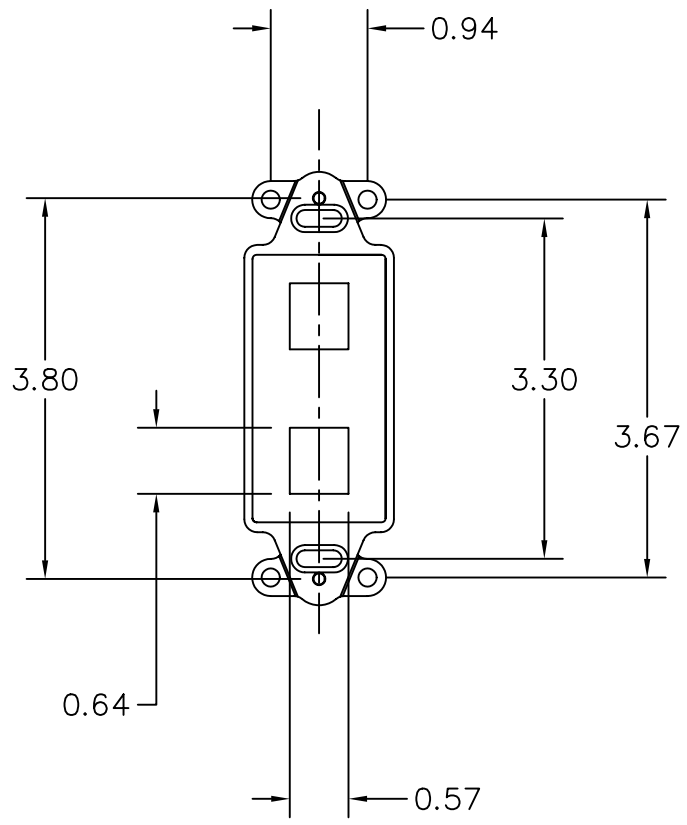

SCREW, MOUNTING

NOTES:  
 1. XXX INDICATES COLOR  
 WHT = ELECTRICAL WHITE

2	2	-	SCREW, 6-32 TYPE F, CHROME PLATED
1	1	10600-PDF2	FRAME DECOR, 2-PORT
ITEM	QTY	PART NO.	DESCRIPTION



e-mail.....info@dynamcomcorp.com  
 1366 San Mateo Ave Suite 201  
 South San Francisco CA 94080

TITLE		CHECKED:	
2-PORT FRAME FOR DECOR WALLPLATE		DWG. NO.	SHEET 1 OF 1
		10600-PDF2-XXX	REV.

4

3

2

1

THE INFORMATION CONTAINED HEREON IS PROPRIETARY AND CONFIDENTIAL TO DYNACOM CORPORATION AND SHALL NOT BE USED OR DISCLOSED, IN WHOLE OR IN PART WITHOUT FIRST OBTAINING THE WRITTEN PERMISSION OF DYNACOM CORPORATION. SPECIFICATIONS ARE SUBJECT TO CHANGE WITHOUT NOTICE.

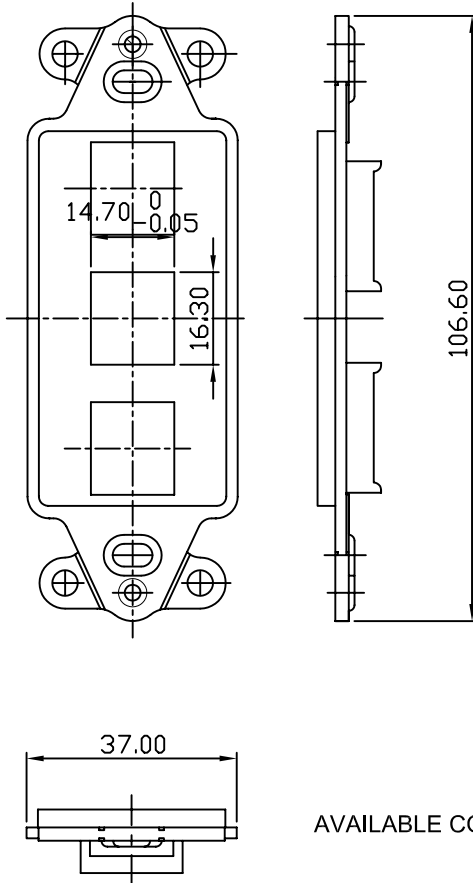

AVAILABLE COLORS: ELECTRICAL WHITE

UNLESS OTHERWISE SPECIFIED: TOLERANCES		PROJECT ID 10600-PDF3-XXX		TITLE	
INCH	MM	ANGULAR	FILE	DATE	3-PORT FRAME FOR DECOR WALLPLATE
.X ± .016	.X ± 0.2	X ± 1°			
.XX ± .008	.XX ± 0.1	.X ± .5°			SIZE
.XXX ± .004					DRAWING NUMBER
					PART NUMBER
					REV
MATERIAL	DRAWN				SCALE
SURFACE	CHECK				UNIT
FINISH	APPROVED				mm
					SHEET

D

C

B

A

4

3

2

1

THE INFORMATION CONTAINED HEREON IS PROPRIETARY AND CONFIDENTIAL TO DYNACOM CORPORATION AND SHALL NOT BE USED OR DISCLOSED, IN WHOLE OR IN PART WITHOUT FIRST OBTAINING THE WRITTEN PERMISSION OF DYNACOM CORPORATION.  
 SPECIFICATIONS ARE SUBJECT TO CHANGE WITHOUT NOTICE.

D

C

B

A

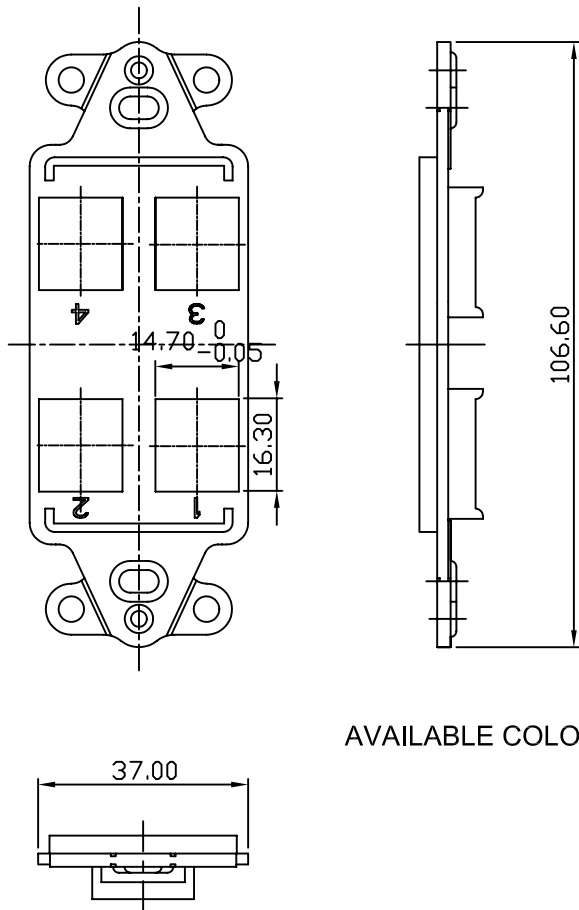

AVAILABLE COLORS: ELECTRICAL WHITE

UNLESS OTHERWISE SPECIFIED: TOLERANCES		PROJECT ID 10600-PDF4-XXX		TITLE 4-PORT FRAME FOR DECOR WALLPLATE	
.X ± .016	.X ± 0.2	X ± 1°	FILE	DATE	
.XX ± .008	.XX ± 0.1	.X ± .5°	MATERIAL	DRAWN	
.XXX ± .004			SURFACE	CHECK	
			FINISH	APPROVED	
SCALE		UNIT	mm	SHEET	

