

1 THE INFORMATION CONTAINED HEREON IS PROPRIETARY AND CONFIDENTIAL TO DYNACOM CORPORATION. AND SHALL NOT BE USED OR DISCLOSED, IN WHOLE OR IN PART WITHOUT FIRST OBTAINING THE WRITTEN PERMISSION OF DYNACOM CORPORATION.

ZONE	REV.	DESCRIPTION	DATE	APPV.
-	A	INITIAL RELEASE	05/15/2014	E.A.

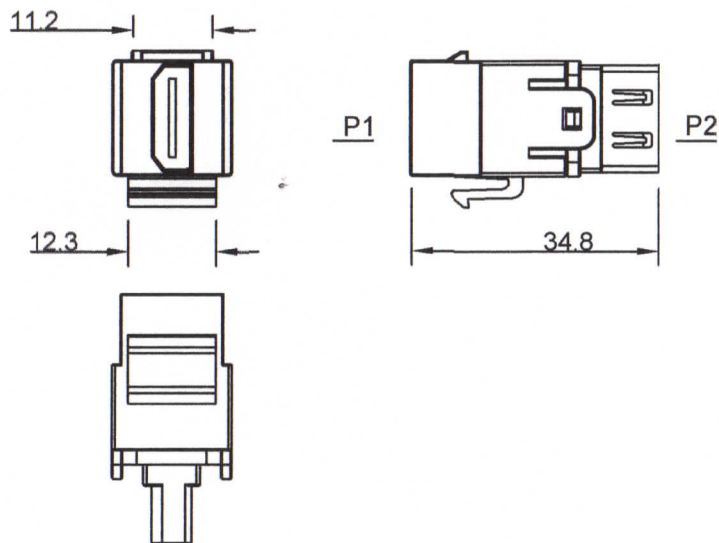
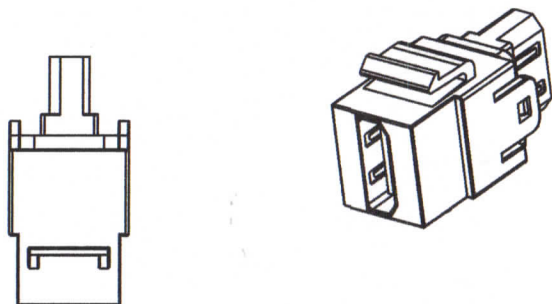

	P1	P2
1	---	1
2	---	2
3	---	3
4	---	4
5	---	5
6	---	6
7	---	7
8	---	8
9	---	9
10	---	10
11	---	11
12	---	12
13	---	13
14	---	14
15	---	15
16	---	16
17	---	17
18	---	18
19	---	19
SHELL	---	SHELL

NOTES:

- ELECTRICAL CHARACTERISTICS :
  - RATING CURRENT: 0.5A;
  - RATING VOLTAGE: 40V;
  - CONTACT RESISTANCE: 30m OHMS MAX.
  - INSULATION RESISTANCE:
    - UNMATED: 100M OHMS MIN.AT 500 VDC
    - MATED: 10M OHMS MIN.AT 150 VDC
  - DIELECTRIC WITHSTANDING VOLTAGE: 500VAC/1MINUTE
  - OPERATING TEMPERATURE: -20°C--+85°C
  - STORAGE TEMPERATURE: -20°C--+65°C
  - OPERATION /STORAGE HUMIDITY:95% OR LESS.
- MECHANICAL CHARACTERISTICS :
  - INSERTION FORCE : 44.1N(MAX)
  - EXTRACTION FORCE: 9.8N(MIN):39.2N(MAX)
  - MATING CYCLE: 5000 CYCLES:
  - CONTACT PULL OUT FORCE: 5.8N/PIN(MIN)
  - PLASTIC MATERIAL: ABS 94V-0.
- HOUSING: ABS 94V0
- PCB: FR-4 Tin PLATING (LEAD FREE)
- CONN: HDMI 19P FEMALE.
 

INSULATION: ENGINEERING THERMOPLASTIC BLACK;  
CONTACT: COPPER ALLOY, GOLD OVER NICKEL PLATED;  
SHELL: BRASS, GOLD FLASH PLATING



e-mail...sales@dynacomcorp.com  
www.dynacomcorp.com

TOLS ~ 20MM ± 0.2MM, OVER 20MM TO 60MM ± 0.4MM, OVER 60MM ± 0.8MM. ANGLES ± 1 DEG

NEXT ASSY: -	DRAWN: E.A. 07/01/2014	CHECKED: EA
TITLE	DWG. NO.	SHEET 1 OF 1
HDMI Coupler Insert, White	10600-HDMI-WH	REV. A